

# ***Dynemix India***

// *Concept To Creation*



[sales@dynemix.com](mailto:sales@dynemix.com) | [www.dynemix.com](http://www.dynemix.com)

+91 990 413 6300 | +91 990 413 6900

- ▶ Tubular and Through Screw Conveyor
- ▶ Belt Conveyor
- ▶ Dence Phase System
- ▶ Micro Batch Feeder
- ▶ Storage Silos & Accessories
- ▶ Drag Chain Conveyor
- ▶ Bucket Elevator
- ▶ Tube Chain Conveyor
- ▶ Pneumatic Conveying System

## Tubular and Trough Screw Conveyor



Screw conveyors are bulk material transportation system composed of a rotating, spiral screw inside tubular casing or a trough. As the screw rotates, dry or semi dry bulk material is pushed forward through the conveyor from one area to another. Screw conveyor systems handle all kinds of different substances, including powder, dust, flakes, granules etc.

## Belt Conveyor



Belt Conveyor, any of various devices that provide mechanized movement of material, as in a factory; they are used principally in industrial applications but also on large farms, in warehousing and freight-handling, and in movement of raw materials. Conveyors may be only a few inches in length, or they may be integrated systems several meters long.

## Dense Phase System



Dense Phase Pneumatic Conveying is a method for moving difficult, abrasive or friable materials, at slow speed. It pushes material along an enclosed pipe, in a plug form, using small amounts of gas, at a low pressure and high-volume positive displacement. Most commonly, the process will mean moving material from a single collection point to either a single or multiple reception points.

## Micro Batch Feeder



The Micro-Batch Feeders for powder and granular product feeding are particularly suitable for poorly flowing materials which tend to clog, along with adhesive products. The MBFs are also beneficial for the nominal flow of high & low dense material in the application of volumetric feeding.

## Pneumatic Conveying System

The principle of pneumatic conveying is based on the fact that bulk goods can be moved by means of air through pipelines. The flowing conveying air transmits a propulsion force on the bulk material and thus conveys it through the conveying line. DYNEMIX INDIA combines modern computerized technology with innovative mechanical and pneumatic design to produce ingredient handling systems that not only free operators of physical effort but also perform sophisticated pneumatic conveying operations with little human assistance. Each system we design is custom engineered for the application parameters provided by the customer, to ensure that the system will perform to exact requirements.

## Storage Silos & Accessories



Bulk materials in powder and granular form are used in wide range of industrial processes. Dynemix provides reliable solutions for bulk solid storage systems and silos from concept design to turnkey installations with complete accessories i.e. Dust filters, level sensors, butterfly valves, Pressure Relief Valve, Actuators, Bin activators and many more.

## Drag Chain Conveyor

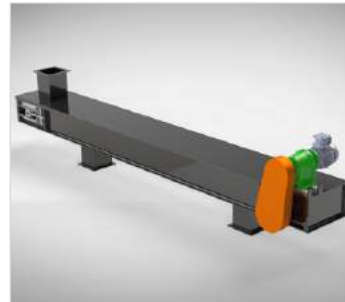

Drag chain conveyors work on the Principle of a chain-and-flight combination pulling a volume of material along. The chain is equipped with different flights/paddles and drags the material from various charging points to a number of discharging points.

## Bucket Elevator



The Bucket Elevators comes in three basic types: centrifugal, continuous, and positive discharge conveyors according to the applications. Bucket elevator mostly used for the granular and solid material to convey vertically at higher elevation and small as well.

## Tube Chain Conveyor



A tube chain conveyor moves materials inside a tube, pulled by a chain. It offers a convenient way for conveying bulk material from one location to another, and also multi-axially. Tube chain conveyors are used for transporting, feeding, dosing, distributing and discharging pourable bulk materials.

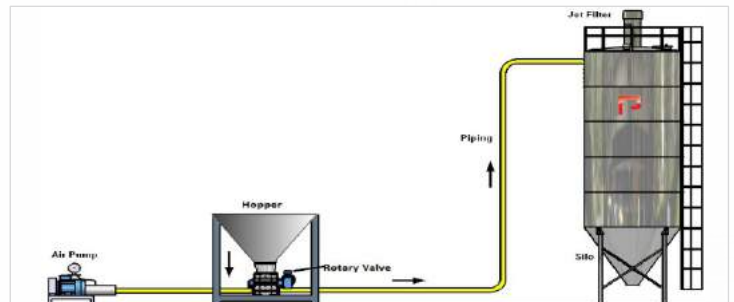

- ▶ Lime Powder Handling System
- ▶ Slurry Preparation Plant-Batch Type
- ▶ Slurry Preparation Plan-Continuous Type
- ▶ Customized Bag Slitting Machine
- ▶ Automatic Bagging & Bag Conveying System

## Lime Powder Handling System



Dynemix is one of the Manufacturer and supplier of lime handling system within and outside the India. Our pneumatic conveying systems include Bulker and Jumbo Bag unloading, bulk storage, and silo-to-silo conveying designed for each specific application. Dynemix's extensive knowledge of particle characteristics and flow behaviour, plus experience with various material results in a reliable and cost-effective solution.

**Client:** UPL Limited (Unit-1)  
**Supply:** Lime Handling System

**Material:** Lime Powder  
**Location:** Ankleshwar, Gujarat

## Slurry Preparation Plant - Batch Type

Raw Material comes from shovel is being transferred to the Storage Silos by Pneumatic Conveying System. The Roots Blowers are connected with Diverter valve to switch over to the standby roots blower. Storage Silos are equipped with required accessories to monitor and operate the material flow. Screw Conveyors at the bottom of Silos transfers the material towards Weighing Hopper. The weighing hoppers are equipped with the required accessories and accessible platforms, railings and ladder for maintenance.

**Client:** Metito Overseas, Qatar  
**Supply:** Lime Preparation Unit

**Material:** Hydrated Lime  
**Location:** Doha-Qatar



## Slurry Preparation Plant - Continuous Type



Raw Material comes from Jumbo Bag or Bulker is being transferred to the Storage Silos by Pneumatic Conveying System. The Roots Blowers are connected with Diverter valve to switch the Flow between Bulker Line and Jumbo Bag Unloading Station. Storage Silos are equipped with required accessories to monitor and operate the material Flow. Screw Conveyors at the bottom of Silos transfers the material towards Lime Slaker. Lime Slaker stands to create the Lime Slurry with desired recipe and further removes unnecessary gret and transfer fine goods to Slurry Tank.

**Client:** GRASIM Industries Limited  
**Supply:** Lime Slurry Production Plant

**Material:** Hydrated Lime  
**Location:** Vilayat, Gujarat

## Customized Bag Slitting Machine

Automatic Bag Slitting Machine supplied to remove the Human interaction with the Hazardous material. Automatic Bag Slitting Machine Cut the Bag and transfer the material towards the defined utility as per requirement. First the bag passed through the belt conveyor and transferred to the Bag Slitting Unit. Bag Slitting Unit will cut the bag and unload the material in to the Material Hopper. Material Hopper consisting of a vibrator to make proper unloading and it will further pass the material to Weighing Hopper as per requirement.

**Client:** Aarti Industries Limited  
**Supply:** Automatic Bag Slitting Machine

**Material:** Customized Material  
**Location:** Vapi, Gujarat



## Automatic Bagging & Bag Conveying System



Bag Conveying System is a combination of different Belt Conveyors with Compatible attachments and spacing. All the conveyors are having a separate Motor Gearbox Drives. Empty bags are placed at the first conveyor and it is a mounted-on Load cell. One Weighing Indicator with Cabinet is placed at eyesight level to read the weight reading of bag. After completion of filling, the bag is transferred further and flipped from vertical to horizontal orientation by means of a Special Attached Mechanism In the length of conveyor there is one Bag Counting sensor is provided to maintain the production record.

**Client:** UPL Limited (Unit-1)  
**Supply:** Automatic Bag Stitching and Conveying System

**Material:** CaCl<sub>2</sub>-2 Bags  
**Location:** Ankleshwar, Gujarat

- ▶ 20-25 Kg Bagging System
- ▶ Solid Material Conveying System
- ▶ Material Handling System for Reactor Batch Charging

- ▶ Lime Feeding System of Boiler
- ▶ Sludge Conveying System

## 20-25 kg Bagging System



Dynemix India provide complete turn-key solution for your Automatic Bagging Machine System requirement. A variety of materials and bulk products are packaged by using open mouth Falling systems. The process of involves feeding, weighing and dumping into the bag which is clamped on a pneumatic holder. The bags are picked and placed automatically by the bag placer system. The bag is then released and dropped onto a conveyor.

**Client:** Aarti Industries Limited  
**Supply:** Automatic Bagging System  
**Material:** CaCl<sub>2</sub>-2H<sub>2</sub>O (Calcium Chloride)  
**Location:** Jhagadiya, Gujarat

## Solid Material Conveying System

The Raw material source of 25-50 kg bags unloaded in to the Manual Dumping Station and the material conveyed to the vibrating screen by belt conveyor. Vibrating screen separates the material as per the required particle size and the same will be conveyed to the bucket elevator by Drag chain conveyor. The Bucket elevator further convey the material into the weighing hopper by another drag conveyor. The weighing hoppers of defined capacities are being filled respective to the application and the actuated knife gate valves are placed to restrict and allow the flow of the material.

**Client:** UPL Limited (Unit-12)  
**Supply:** CPC Handling System  
**Material:** Calcite Petroleum Coke  
**Location:** Dahej, Gujarat

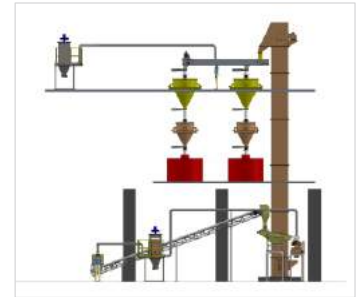
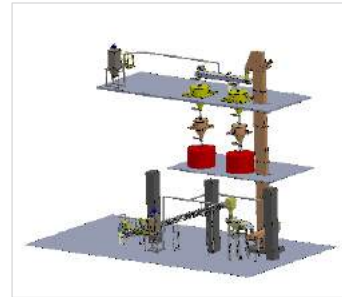

## Material Handling System For Reactor Batch Charging



The Material Handling System for above mentioned powder and liquid is produced to maintain the recipe and quality of fine goods. The Dense Phase System placed at the procurement store to convey the Raw Material of Powder comes from the bags. Roots blower is attached to make pneumatic conveying of material The material comes from the Dense Phase directly conveyed to the Header. These all material coming from the bag is being collected into the Header and transferred pneumatically to the respective Storage Silo. All Storage Silos are equipped with required accessories and at the bottom of Silo Screw Conveyor is provided to charge the Weighing Hopper.

**Client:** FAITH Industries Limited  
**Supply:** Material Handling System  
**Location:** Ahmedabad, Gujarat  
**Material:** Powder - Cao, TBLS, PbO, CaCo<sub>3</sub>, PEW, Liquid - BPA, RM-8, RM-9

## Lime Feeding System of Boiler

Lime feeding system of boiler is designed and supplied on the basis of the requirement of the feeding lime in to the boiler with coal. As far as the pollution control norms of the Indian government is concerned the coal with percentage feeding of lime is protecting the exhaust gases with the hazardous dioxides and trioxides of the Sulphur and Nitrogen. This system is being synchronized with the coal feeder and accordingly it will make the feed of lime as per the process requirement. The system is completely supplied with the programmable PLC panel and MCC panel.

**Client:** Aarti Industries Limited  
**Supply:** 14 TPH Boiler Lime Feeding System  
**Material:** Lime Powder  
**Location:** Dahej, Gujarat

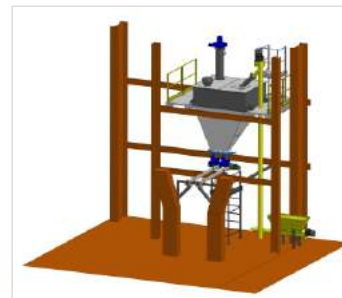

## Sludge Conveying System

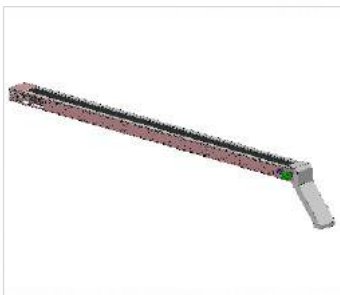

The system comprising of the heavy-duty belt conveyor with the safety accessories like pull cord switch & zero speed switch. This system is designed in application for the sludge coming out from the number of filter presses are being transferred to the material dumping truck by a belt conveyor and it is completely enclosed by the close covered canopy. Also, the system having a sludge conveying passage duct of mirror finished stainless steel material to avoid the settling. This belt used for the system is optimally selected for the application of conveying the sludge and it is also compatible for the high temperature and heat.

**Client:** Aarti Industries Limited  
**Supply:** Sludge Handling Conveyor System  
**Material:** Sludge  
**Location:** Dahej, Gujarat

## Dust Collector



Dust Collectors are equipped with a cylindrically shaped steel body and flanged ring which contains vertically mounted filter bags of various types. An air jet filter element cleaning system is integrated in the top cover. Dust Collectors are available with or without suction fans.

## Lump Breaker



The lump breaker is ideal for making a breaking operation of material having a tendency to form clumps. The rapid rotation of the blades causes the fragmentation of clods. The fast rotation of specially shaped blades through a fixed mesh gives an efficient lump breaking action.

## Agitators



We endow our customers with an enviable range of Liquid Agitators that have a huge demand and serve a wide number of industrial applications. These are primarily used for mixing and blending various types of liquids namely semi – liquids and others.

## Automatic Bag Slitting Machine



The Automatic Bag Slitting Machine is a versatile automatic emptying machine and earns its name owing to its ability to empty any type of bag be it paper, or HDPE of 25 - 50 kgs capacity. The main application of this machine is to load the desired material storage.

## Jumbo Bag Loading and Unloading Station

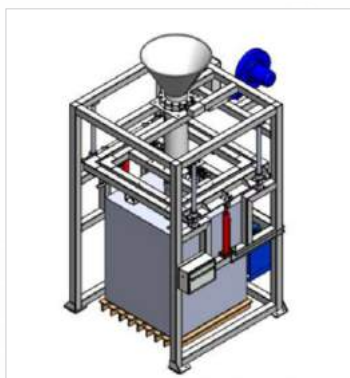

Dynemix India Bulk Bag Unloading Systems, also known as Bulk Bag Dischargers manufacturers of material handling equipment, is specifically designed to provide an easy, clean and economical way to discharge the entire contents of bulk and semi-bulk bags, especially when the material is less than free-flowing. Our massage paddles have a proprietary design to discharge the contents of the bag dust-free into your process, to a Pneumatic Conveying System, a Flexible Screw Conveyor or an Aero-Mechanical Conveyor.

### Key Features:

- Heavy Duty Welded Tubular Frame Construction
- Lift Off Guards protecting plant personnel
- Lift out corner panel and Quick Release massage paddles for cleaning and maintenance
- Partial Bag Cut-off

## Vibrating Screen



General-purpose screening machines for fractioning or protective screening with 1 to 3 decks. Vibrating Screen made with a screening surface vibrated mechanically at high speeds and used especially for screening ore, coal, or other fine dry materials.

## Manual Bag Dumping Station

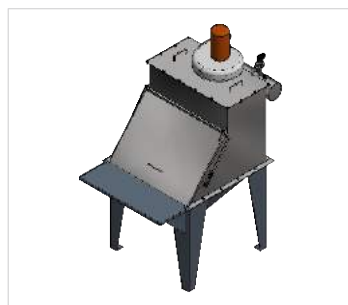

Bag dump stations are designed to minimize dust emissions during the manual process of bag opening and dumping. The system reduces material waste and eliminates the need to clean a remote dust collection site, while protecting workers and preventing plant contamination.

## Actuated and Manual Slide Gate Valve



Actuated Slide Gate Valves are made with utmost accuracy and are very reliable. Our engineers design valve after collecting all technical information from the clients – hence each valve offered to the client is exactly suitable to the application.

## Lime Slaker



High-consumption lime industry use Dynemix lime slacker to convert hydrated lime or raw lime into lime slurry. Typically, a Lime slacker is comprised of two chambers. The first chamber is called the slaking chamber and the second chamber is usually used as a grit removal chamber.





**Appreciation Letters**

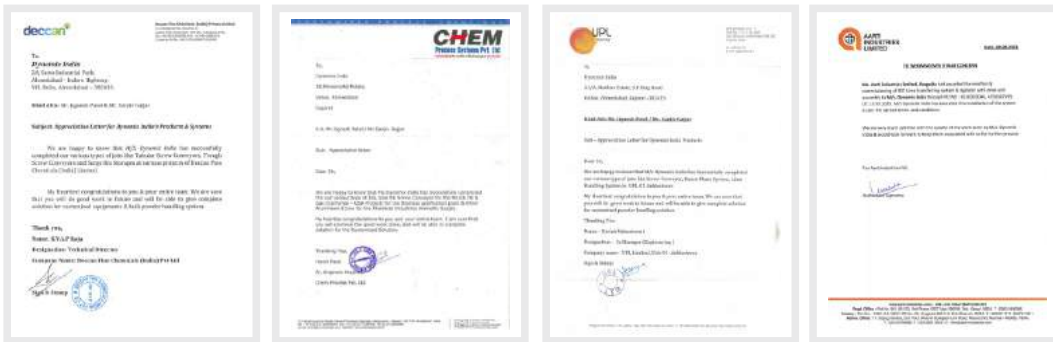

**OFFICE ADDRESS**

21, Madhav Estate, Opp.Girivar Pride, S.P.Ring Road,  
Odhav, Ahmedabad-382415, Gujarat, India

**WORK ADDRESS**

2A, Satva Industrial Park, Ahmedabad – Indore Highway  
No. 59, Village: Kuha (Kothiya), Ta. Daskoi,  
Ahmedabad- 382433, Gujarat, India.

- +91 990 413 6300
- +91 990 413 6900
- sales@dynemix.com
- www.dynemix.com

